

PREFIX	LABEL	QTY.	CARTON
S-	0		1000186
U-	1		1000186
R-	1		1005228

SUFFIX	LEFT BLOCK	RIGHT BLOCK	TRIPLEX GRND. QTY.
NONE	1031738	NONE	-
-TG	1031738	1000394	1
-TG-KK	1101813	1000394	1

SUFFIX	SMALL HUB TYPE	HUB / SCREWS
-RL	HUB OPENING	NONE
-XL	CLOSING PLATE (A7551)	1028222
-WL	1" (A7514)	1028195 / 1156422 (4)
-YL	1 1/4" (A7515)	1000006 / 1156422 (4)
-ZL	1 1/2" (A7516)	1003422 / 1156422 (4)
-DL	2" (A7517)	1000007 / 1156422 (4)
-DL-HS	2" (A7517)	1000007 / 1157607 (4)
-EL	2 1/2" (A7518)	1028196 / 1156422 (4)

ITEM	QTY.	PART NUMBER	DESCRIPTION
1	1	1004913	SHELL WELDMENT
2	1	(SEE CHART)	UNIT HUB
3	1	1123141	FRONT ASSY.
4	2	(SEE CHART)	BLK ASSY 2/0 100 AMP RINGLESS
5	2	1000164	WIRE METER SUPPORT
6	1	1000083	CONNECTOR 2/0
7	2	1000389	2/0 NUT CONNECTOR
8	S/C	1000394	TRIPLEX/QUADPLEX GND. ASSY
9	4	1000060	SCW 10-32 X 5/8 SLT HX WSHR
10	1	1000062	SCREW 10-32 X 3/8 T/F
11	S/C	1000166	LABEL, UL METER SOCKET
12	1	1224705	LABEL, RATING (LOC. B)
13	1	1000158	PAD WIREMAN, 8.37 x 7.50
14	1	1000064	LABEL, DANGER
15	1	(SEE CHART)	CARTON (NOT SHOWN)

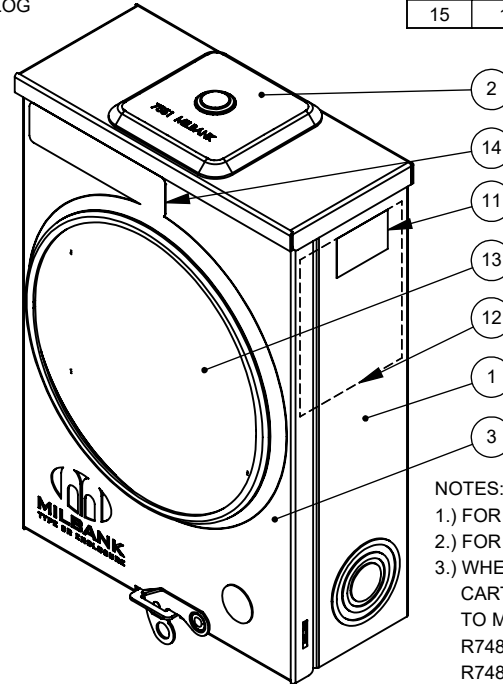
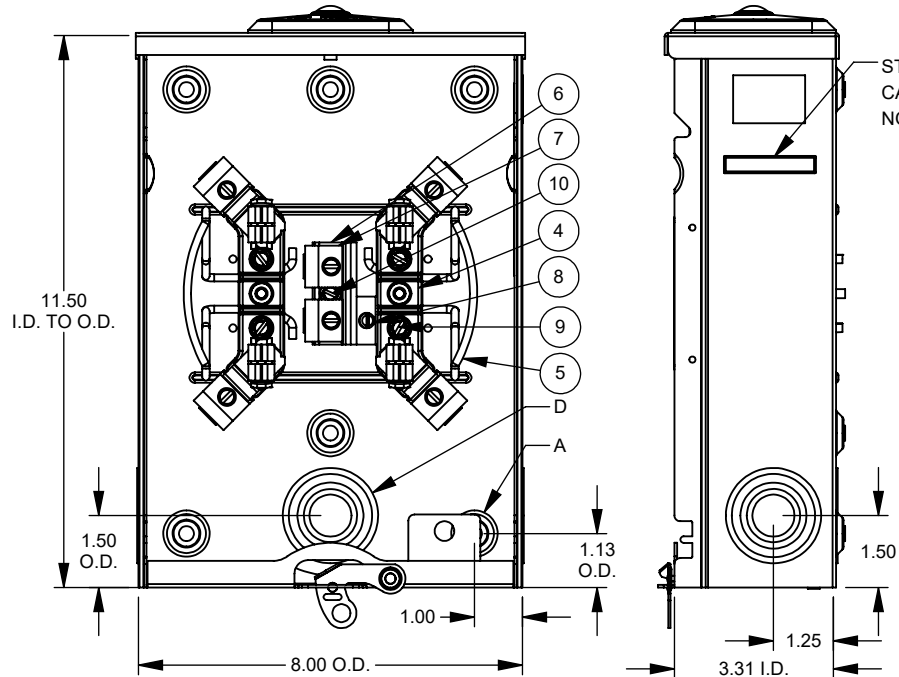

NOTES:
 1.) FOR LABELING LOC. SEE DWG. #1096668.
 2.) FOR FIELD INSTALLED FIFTH TERM. ASS'Y ORDER CAT. #5T8K2.
 3.) WHEN SOLD W/ "R" PREFIX, UNIT TO BE SINGLE PACKED IN CARTON #1005228. APPLY CARTON LABEL FROM LIST BELOW TO MIDDLE OF CARTON SIDE PANEL:
 R7487-YL-TG-KK-BLG: #1130562
 R7487-RL-TG-KK-BLG: #1130563

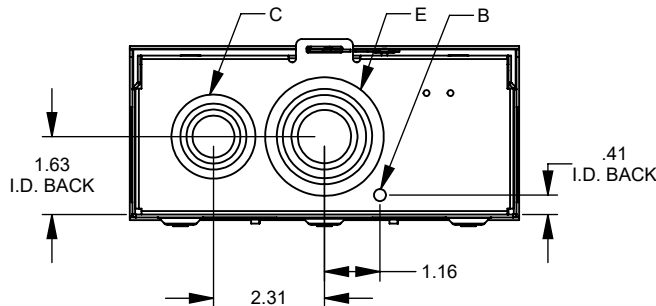

FEATURE TABLE		
ITEM	QTY.	DESCRIPTION
A	6	U/L MNTG. EMBOSS
B	1	1/4 SOLID K.O.
C	1	1/2, 3/4, 1, 1 1/4 CONC. K.O.
D	3	3/4, 1, 1 1/4, 1 1/2 CONC. K.O.
E	1	3/4, 1, 1 1/4, 1 1/2, 2 CONC. K.O.

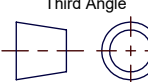
Material:	16 GA. GALV. STL.	 <p>KANSAS CITY, MO USA</p>
Shear/Die No.:		
Finish:	MILBANK LIGHT GRAY	Title: 125A 4T/5T/6T RL OU METER SOCKET
Part Wt.:	8.318 LBS. EA.	
Square Inches:		Catalog No.: ()-7487-()-BLG
Tolerances:	Unless Specified Otherwise X.X ±.1 X.XX ±.03 X.XXX ±.015 X* ±2*	
Scale:	NTS	Customer: ASSO. ELEC.
Checked By:		
Third Angle		Drawing No.: 7487-81
Drawn By:	BNM	
Approved By:		Date: 04/26/17
		Sheet: 1 of 1

REV.	DATE	DESCRIPTION	ECO No.	BY
11	1/5/18	REMOVED -5T SUFFIX FROM BLOCK ASSY CHART. REMOVED NOTE #3	037982	KSP
12	1-17-19	PICTORIAL UPDATE	040528	EH
13	09-23-20	1224705 WAS 1000051, REM SHEET 2	044588	JRK